

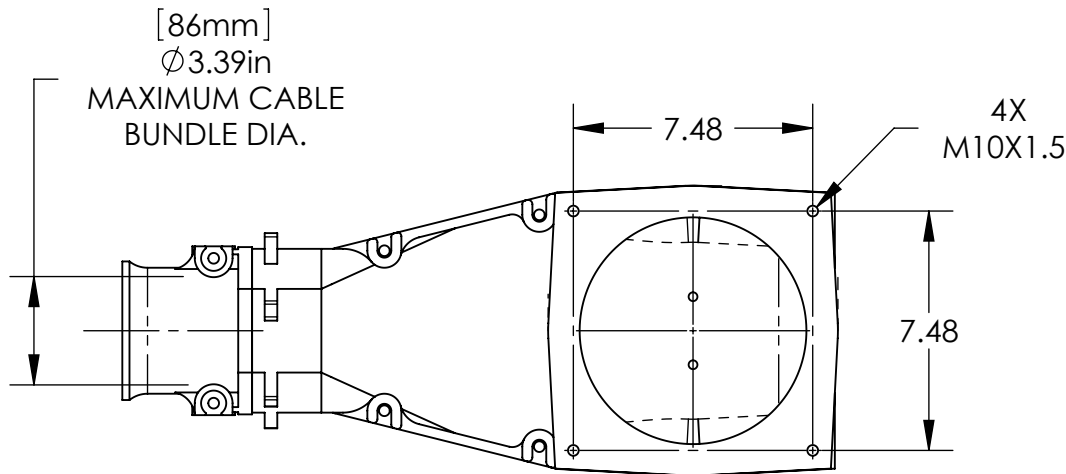

This drawing is the property of MELTRIC Corporation, Franklin (Milwaukee), Wisconsin, USA. Any unauthorized copying of this drawing by any means, ENGR/D06 REV: 20 ISSUED DATE: 1/15/11 or disclosure of its contents to any person not authorized by MELTRIC Corporation or its agents to receive it, is strictly prohibited.

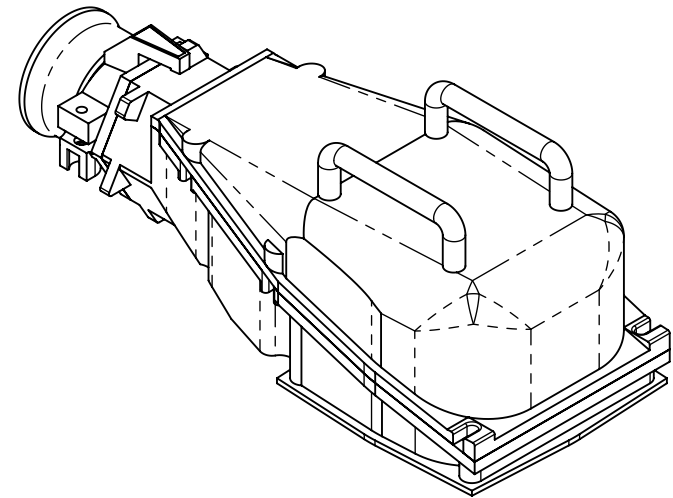
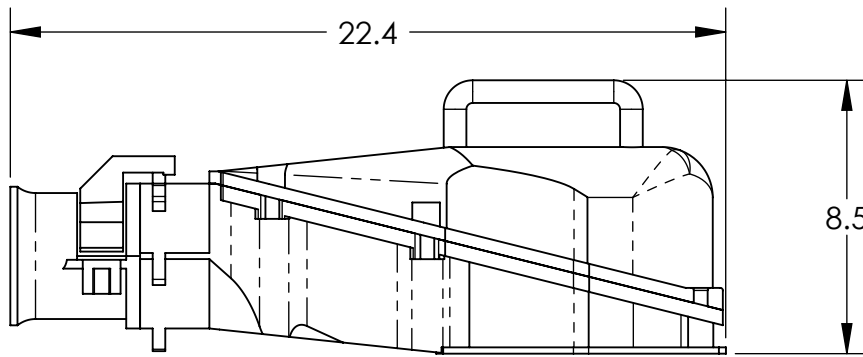

PART NUMBER	CABLE RANGE
49-3A913-200	2.000" - 2.125"
49-3A913-225	2.125" - 2.250"
49-3A913-237	2.250" - 2.375"
49-3A913-250	2.375" - 2.500"
49-3A913-275	2.500" - 2.750"
49-3A913-300	2.750" - 3.000"
49-3A913-312	3.000" - 3.125"
49-3A913-335	3.125" - 3.350"
49-3A913-350	3.350" - 3.390"

APPROX WEIGHT = 15 LBS.

TOLERANCES UNLESS OTHERWISE SPECIFIED	
MACHINED SURFACES $\sqrt[125]{\text{MAX}}$	ENGLISH 0.X ±0.05 0.XX ±0.01 0.XXX ±0.005
GROUND SURFACES $\sqrt[32]{\text{MAX}}$	
ANGLE TOLERANCE ±1°	
REMOVE BURRS & SHARP EDGES TO .015 MAX.	
 DIMENSIONS SHOWN IN OVALS ARE INSPECTION DIMENSIONS.	

		DRAWING TITLE:	
DRAWN	APPROVED	PF300 METAL 90° ANGLED HANDLE	
DATE:	SCALE	MATERIAL:	
	NTS	PAINTED METAL	
SHEET:	PART NUMBER		REVISION
1 OF 1	49-3A913		