

This drawing is the property of MELTRIC Corporation, Franklin (Milwaukee) Wisconsin, USA. Any unauthorized copying of this drawing by any means, ENG/RD/06 REV: 20 ISSUED DATE: 11/15/11 or disclosure of its contents to any person not authorized by MELTRIC Corporation or its agents to receive it, is strictly prohibited.

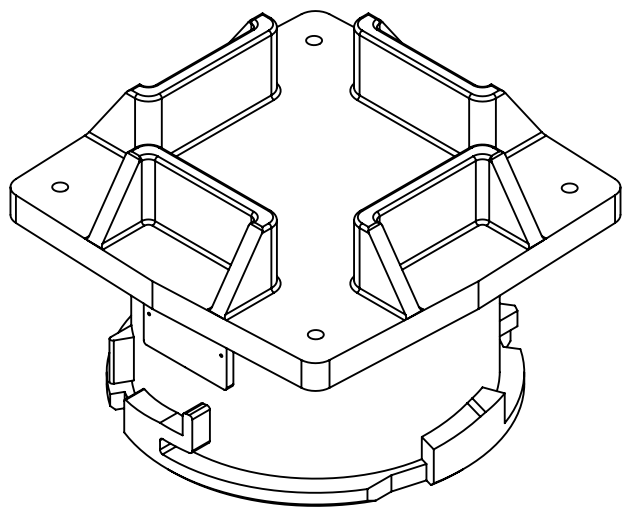
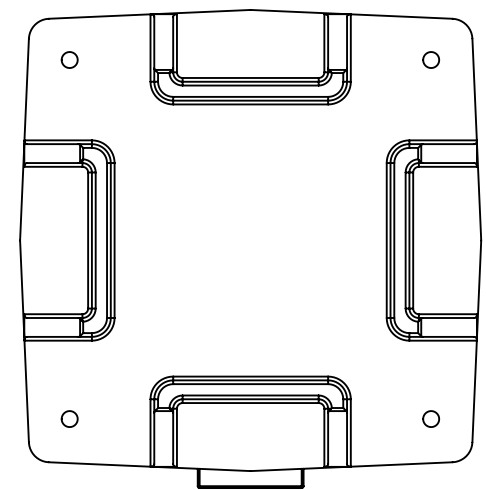
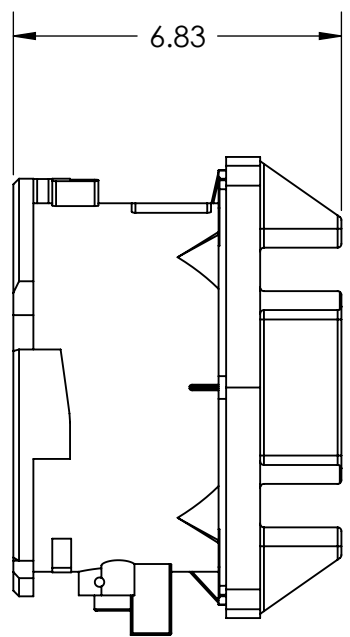
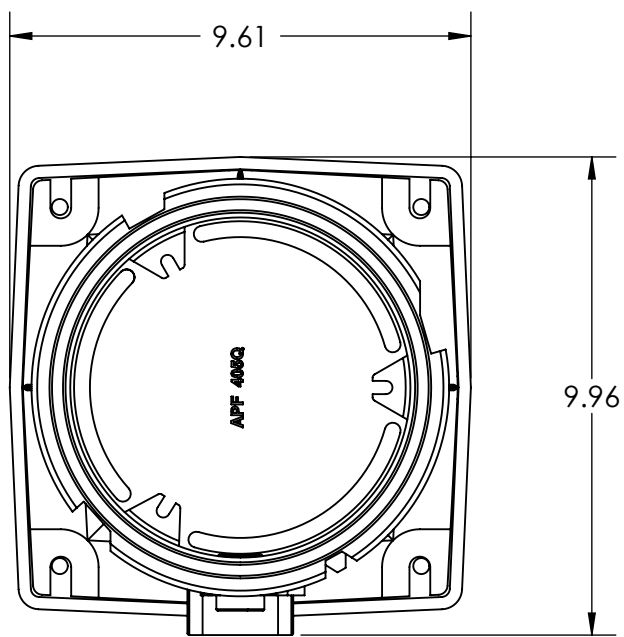

APPROX WEIGHT = 12 LBS.

TOLERANCES UNLESS OTHERWISE SPECIFIED				DRAWING TITLE:	
MACHINED SURFACES $\sqrt{125}$ MAX	ENGLISH			PF300 INLET REPLACEMENT METAL CAP	
GROUND SURFACES $\sqrt{32}$ MAX	0.X ±0.05	DATE:	SCALE	MATERIAL:	
ANGLE TOLERANCE ±1°	0.XX ±0.01		NTS	PAINTED METAL	
REMOVE BURRS & SHARP EDGES TO .015 MAX.	0.XXX ±0.005	SHEET:	PART NUMBER		
DIMENSIONS SHOWN IN OVALS ARE INSPECTION DIMENSIONS.		1 OF 1	49-3A126		