

This drawing is the property of MELTRIC Corporation, Franklin (Milwaukee), Wisconsin, USA. Any unauthorized copying of this drawing by any means, ENG/RD/06 REV: 20 ISSUED DATE: 1/15/11 or disclosure of its contents to any person not authorized by MELTRIC Corporation or its agents to receive it, is strictly prohibited.

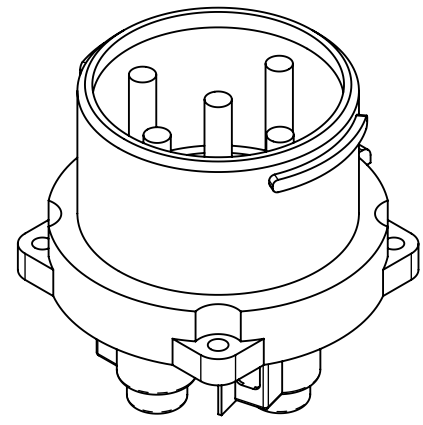
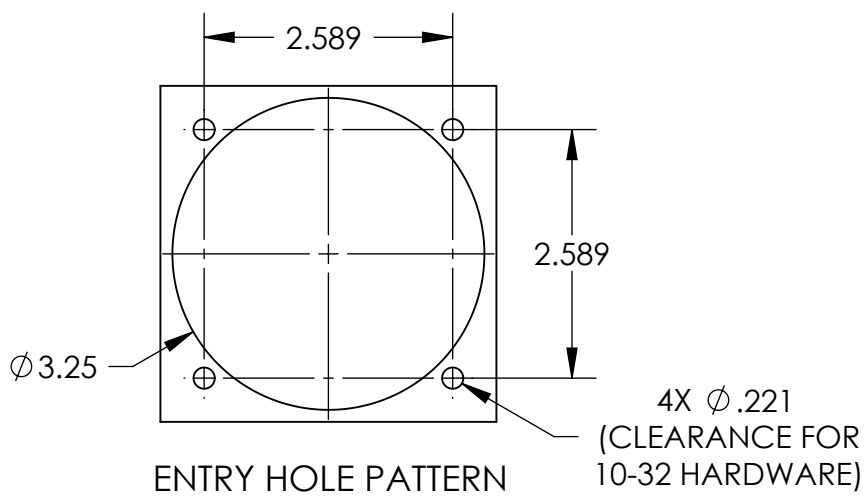
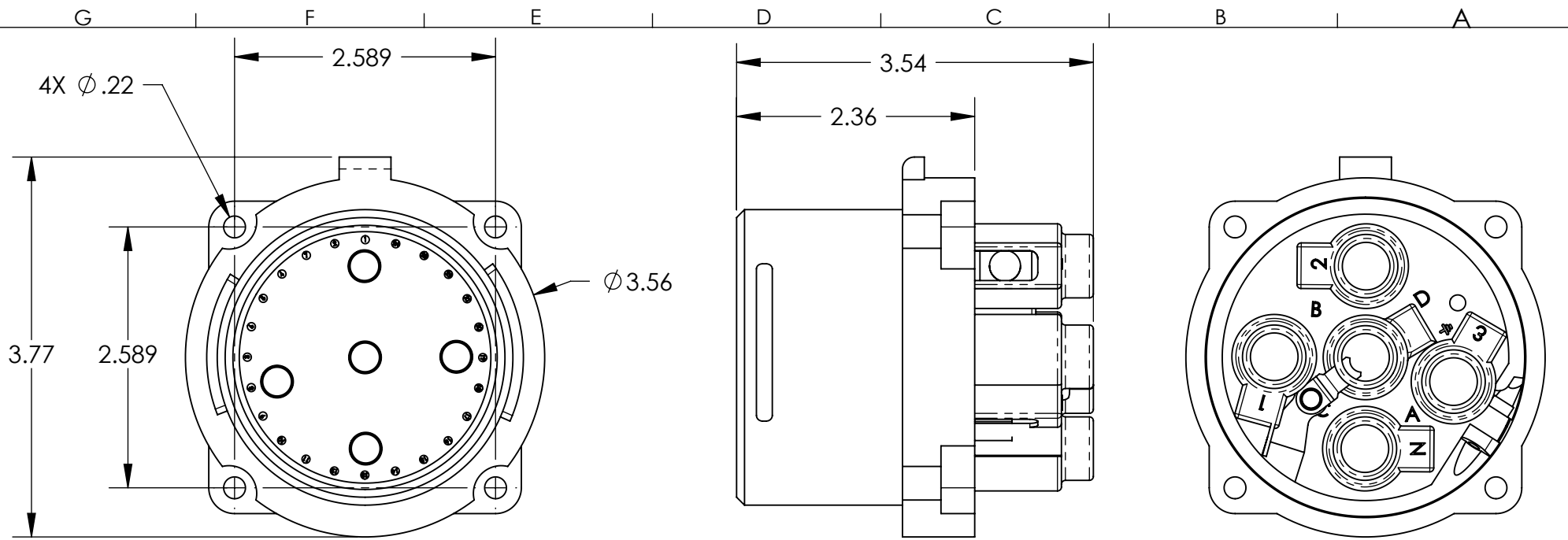

TOLERANCES UNLESS OTHERWISE SPECIFIED				DRAWING TITLE:	
MACHINED SURFACES $\sqrt[125]{\text{MAX}}$	ENGLISH 0.X ±0.05 0.XX ±0.01 0.XXX ±0.005			DRAWN	APPROVED
GROUND SURFACES $\sqrt[32]{\text{MAX}}$		DATE:	SCALE	MATERIAL:	
ANGLE TOLERANCE ±1°		NTS	METAL CASING		
REMOVE BURRS & SHARP EDGES TO .015 MAX.		SHEET:	PART NUMBER		REVISION
DIMENSIONS SHOWN IN OVALS ARE INSPECTION DIMENSIONS.		1 OF 1	37-68xxx		